

Welcome to this issue of Fascinating Facts. Now retired, with a background of journalism, literature production, international public relations, and ex editor of a leading industry publications, I now have the time to combine my abilities and share my interests in historic facts, especially in connection with military matters. While I have written most of the articles in the Scarletman I am happy to accept ideas and contributions from readers; giving them credit for their work. The Scarletman is free issue e-magazine therefore if you would like to circulate copies further then I am happy for you to create a wider readership of those with a similar interest to mine.

In this issue
In this issue
In this issue

3

**THE GOOGOL- A
NUMBER WHICH
CANNOT BE COUNTED**

4

**THE INCREDIBLE
930 YEAR LEANING
TOWER OF PISA**

5

**A TEST OF TIME
WHAT ARE THEY?**

6

**ANSWERS TO PAGE 5.
HOW MANY DID YOU
GET RIGHT?**

7

**DO YOU SEE
THE SAME
COLOUR AS ME?**

8

**WEIRD CRAZY
INVENTIONS**

9

**PHILIPPIDES
AND THE
MARATHON**

10

**ARE THESE
THE OLDEST
PROFESSIONS?**

IN SUPPORT OF UKRAINE

FASCINATING FACTS FOR JULY

July was named after the famous Roman General Julius Caesar as it was the month of his birth. The month was previously called Quintilis (Latin for fifth) the fifth month of the 10-month-long ancient Roman calendar.

As the second month of Summer, July is, on average, the warmest month of the year in the northern hemisphere while in the southern hemisphere it is on average, the coldest month of the year.

Early July was often refer to as the 'dog days of summer' as in ancient Roman and Greek astrology they were connected with bad luck, mad dog attacks, unexpected thunderstorms, heat, and drought.

In July 1885, coincidentally, the rabies vaccine was first successfully given to a child bitten by a dog by French microbiologist Louis Pasteur

On July 5, 1946, the world's first bikini was unveiled in the famous Piscine Molitor swimming pool in Paris. Modelled by showgirl Micheline Bernardini. Although two-piece swimwear existed, none used as little fabric as the bikini.

The Anglo-Saxons had multiple names for the month of July, including Maed-monath and Hey-monath meaning "the flowering of meadows" and "hay month."

On July 4, 1776, the 13 American colonies declared their independence from the British monarchy. The 4th of July, formally known as Independence Day, has been a federal holiday since 1870 in the United States of America.

On July 25, 1909, Louis Bleriot became the first man to fly an aircraft from one country to another. He took off from the coast of France and landed near Dover.

July has two birth flowers – the water lily and the larkspur. The water lily is a symbol of a pure heart, while the larkspur represents the lightness of the heart.

The birthstone of July is the ruby, considered to protect warriors on the field of battle if it embedded in their armor. Also said to protect against evil.

Fascinating Facts is a free circulation e-magazine. If you like it then please make your friends aware. If you would like to submit material for inclusion then, if the editor considers it appropriate, he will inform you. Such material from contributors, for which the editor, while following normal journalistic principles, takes no responsibility. If you have an idea for an article you consider would be of interest then please contact the editor. Establishing copyright is a complex issue and while every effort has been made, to secure permission for copyright of material used, if it has been inadvertently used a future issue will carry an acknowledgement. While the editor reserves the right to grant permission to use any material from this publication for reproduction, any reasonable request will be positively considered. To register for regular monthly copies contact the Editor Ray Pearson 07813648702 or email ray@scarletman.co.uk

THE INCREDIBLE 930 YEAR LEANING TOWER OF PISA

While the picture of the leaning Tower of Pisa makes one wonder why it has not collapsed, walking round it reinforces that opinion.

Designed as a freestanding bell tower, of Pisa Cathedral it has a nearly four-degree lean, the result of an unstable foundation. The 186 ft tower, with 8 floors and about 296 steps, is one of three structures in the Pisa's Cathedral Square which includes the cathedral and Pisa Baptistery.

A research study in 2001 indicated that Diotisalvi was the original architect, by comparison with his other works, notably the bell tower of San Nicola and the Baptistery, in Pisa.

STAGED CONSTRUCTION

Constructed in three stages over 199 years work on the foundation started in 1173. following Donna Berta di Bernardo, who bequeathed sixty soldi to purchase a few stones to form the base of the tower, following which the foundations of the tower were officially laid. Work on the ground floor started on 14 August.

The tower began to sink five years later when construction reached the second floor due to inadequate foundations, in weak, unstable subsoil.

The building of the tower was flawed from the beginning. So construction was halted for almost a century, due to the Republic of Pisa being almost continually engaged in local battles. During this time the underlying soil settled.

LOCAL MARBLE

On 23 February 1260, Guido Speziale was elected to oversee the building of the tower. On 12 April 1264, master builder Giovanni di Simone, architect of the Camposanto and 23 workers cut the marble from the local mountains. The stones were given to Rainaldo Speziale, in 1272, when construction resumed under Di Simone. To compensate for the tilt, they built upper floors with one side taller than the other.

Due to this, the tower is slightly curved. But construction was halted again in 1284 when the Pisans were defeated by the Genoese in the Battle of Meloria. The seventh floor was completed in 1319 and the



Arne Müsseler / www.ame-muesseler.com, CC BY-SA 3.0 DE, via Wikimedia Commons

bell-chamber was finally added in 1372. This part was built by Tommaso di Andrea Pisano, who succeeded in harmonising the Gothic elements of the belfry with the Romanesque style of the tower.

WITHSTOOD EARTHQUAKES

It has seven bells, one for each note of the musical major scale, the largest one, weighing 652 kg, was installed in 1655. this made the total of seven bells at the top 10,796 kg! Since 1280 at least four strong earthquakes have hit the region but the apparently vulnerable tower has survived against all predictions until a research group investigated and concluded that the tower withstood the tremors due to 'dynamic soil-structure interaction'. This means the height and stiffness of the tower, together with the softness of the foundation soil, influences the vibrational characteristics of the structure in such a way that the tower does not resonate with earthquake ground motion. Nevertheless the soft soil, that caused the leaning and brought the tower to the verge of collapse has also helped it survive since 1280.

It is claimed that between 1589 and 1592, Galileo Galilei, dropped two

cannonballs of different masses from the tower to demonstrate that their speed of descent was independent of their mass, in keeping with the law of free fall.

During World War II, the Allies suspected that the Germans were using the tower as an observation post so a US Army sergeant was sent to investigate, he was so impressed by the beauty of the cathedral and its campanile, he refrained from ordering an artillery strike, sparing it from destruction.

INTERNATIONAL HELP

Numerous efforts have been made to restore the tower to a vertical orientation or at least keep it from collapsing. In 1993, 870 tonnes of lead counter weights were added, which straightened the tower slightly. But most such efforts have failed with some worsening the tilt. Therefore on 27 February 1964, the Italian government requested international aid to prevent it from toppling but not straighten it as it was considered important to retain the current tilt, due to its role in promoting the tourism industry of Pisa.

It was closed to the public on 7 January 1990, after more than two decades of stabilisation studies and spurred by the abrupt collapse of the Civic Tower of Pavia in 1989. The bells were removed to relieve some top heavy weight, and cables were cinched around the third level and anchored several hundred meters away. Apartments and houses in the path of a potential fall of the tower were vacated for safety. The selected method for preventing the collapse of the tower was to slightly reduce its tilt to a safer angle by removing 38 cubic metres of soil from underneath the raised end.

NOW STABLE FOR 200 YEARS

This reduced the tilt by 45 centimetres returning to its 1838 position. After a decade of corrective reconstruction and stabilisation efforts. And it was reopened to the public on 15 December 2001. Following an 11 year phase of structural strengthening, it has been undergoing gradual surface restoration to repair visible damage due to the tower's age and exposure to wind and rain. In 2008, engineers announced that the tower had been stabilised for the first time in its history and stated that it would be stable for at least 200 years.

A TEST OF TIME WHAT ARE THEY? ANSWERS PAGE 6

Every year new gadgets are introduced replacing those used previously. When one knows their use then it becomes obvious to imagine how important they were to everyday living. Of course much of those below were manually operated. So now with electric replacements they have disappeared into the mists of time. Also now with the advancement of technology the design has changed and a different way found to achieve the same outcome. But many have disappeared as so much is now bought ready for use.

A BIT OF LEVERAGE



MODIP
Museum of Design in Plastics



<https://www.iwm.org.uk/collections/item/object/20509360>

A MOOVING EXPERIENCE



Science Museum Group Studio, CC-BY-SA 4.0, via Wikimedia Commons

FILTER DRINKING CUP?



Creative Commons Attribution-NonCommercial-ShareAlike 4.0 Licence

A MOST FEARED ITEM



<https://www.iwm.org.uk/collections/item>

IWM

FOLLOWING IN FOOTSTEPS ITS ALL IN THE NAME



https://coimages.sciencemuseumgroup.org.uk/images/1/310/medium_a121646.jpg

LONG HANDLED SCISSORS?



https://coimages.sciencemuseumgroup.org.uk/images/289/347/medium_1961_0038_0001_.jpg

A FORM OF GRINDER?



Creative Commons Attribution-NonCommercial-ShareAlike 4.0 Licence



Eden-Amalie-Lassen, Bernhard, Anek, E. Rosenmuller, CC-BY-SA 4.0, via Wikimedia Commons

A SPECIAL CUP?



Una Smith, CC BY-SA 3.0, via Wikimedia Common

A MEDICAL DEVICE?



WikivMay, CC BY-SA 3.0, via Wikimedia Commons

MUSHROOM IS A GIVE AWAY

ANSWERS TO PAGE 5. HOW MANY DID YOU GET RIGHT? WHICH WAS THE MOST DIFFICULT?

A MOOVING EXPERIENCE

Car headlight restrictions, where both headlights were masked and the front of the headlights were blanked off except for a narrow 3/8 inch horizontal slot just below the lamp centre line. made night driving during the second world war difficult. It caused many motor accidents and deaths of people and animals. So during the early part of the war an Essex farmer had his herd of black cows painted with white stripes to make them visible to the motorists. in case they should wander on the road after dusk.



FOLLOWING IN FOOTSTEPS

A pair of matching rubber overshoes, cast in the form of bare human feet. Each 'shoe' has tying tapes for fitting over the wearer's conventional boots/shoes. These were made for SOE agents as an aid for deception when operating in the Southeast Asia/Pacific theatres to fool the Japanese. When the agent landed on a beach from the sea it was intended that using these his 'footprints' would make the pursuers think only natives had travelled in the vicinity.



A SPECIAL CUP

My Uncle Harry had a moustache cup; invented in 1870 by potter Harvey Adams to stop the hot chocolate, a luxury at that time, melting the wax used to keep the Victorian moustaches in shape, dripping into the drink, spoiling its taste and staining the moustache.



THE NAME GIVES IT AWAY

This is an accumulator a two-volt battery produced from 1934-and, during WW2. I remember having several and my father getting them charged to power our radio. An accumulator is a lead-acid system, it has plates of lead oxides and an electrolyte of sulphuric acid, and produces two volts of direct current.



WiklyMay, CC BY-SA 3.0, via Wikimedia Commons

MUSHROOM IS A GIVEAWAY Darning socks was a necessary female skill The hole in the sock was placed over the mushroom and the remainder of the sock grasped by the handle. Sock were mostly cotton and using a needle and cotton the skill was to replace the weave and repair the hole.

MEDICAL DEVICE?

This is a cherry pitter for removing the pit from a cherry leaving the cherry intact. There are many styles of cherry pitters from small tools held in the hand, domestic crank-operated machines with a hopper, and industrial machines.



A BIT OF LEVERAGE

When cream was a luxury, it was made at home using milk and butter and a great deal of elbow grease! With their pump action cream makers churned the milk and butter turning into cream. Some of the Jubilee cream makers also had a little pourer adaptor which allowed the cream-maker base to become a cream jug. The Bakelite top colours changed over the decades and by the 60's the tops were replaced by plastic ones.



FILTER DRINKING CUP?

No not used by mouth but by ear. It is a silver-plated ear trumpet, made about 1875. The ivory ear tip sat inside the ear canal and it amplified sounds down the tube. A form of parabolic reflector it projects sound energy onto a focal point - the ear drum, through refraction and reflection. This enables the ear trumpet to be an effective hearing aid while remaining relatively small. This silver-plated example was made by F. C. Rein and Son in London, founded in 1800 and the first company known to manufacture hearing aids commercially.



A FORM OF GRINDER?

In the 1880's ice-cream machines reduced in size enabling people to have them in hir homes.. They typically consisted of a metal inner pail with a paddle attached to a crank handle fitted inside a wooden bucket which was filled with a freezing mixture, of ice, and salt. The cream was then poured in and by slowly turning the handle into the inner bucket where it was churned until frozen. <https://comag.sciencemuseumgroup.org.uk>



LONG HANDLED SCISSORS?

Wrong! It is a 400 year old steel and brass bullet extractor. Attempts had been made to remove bullet-like projectiles when firearms had been introduced into warfare as early as the 1200s. Problem was special instruments were need for removing deeply embedded bullets. As early as the 1500's as firearms became increasingly sophisticated with screw-type bullet extractors like this one were introduced. The screw is lengthened to pierce the bullet to remove it.



<https://comag-es.sciencemuseumgroup.org.uk/>

A MOST FEARED ITEM

A foot operated dentist drill like this was used when, aged 12, I went for my first dental appointment; and no anaesthetic! Invented in 1871 by American dentist James Beall Morrison the dentist has to stand on one leg while holding the drill in one hand and a mirror in the other all the time pumping the other foot to power the drill. Many said that it was a great advancement but from my experience it was slow and excruciatingly painful.

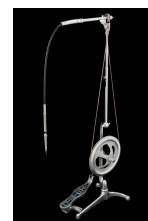



No one can be totally sure that we all see the same colours. What colours we see depends not just on how things are in the world around us, but also on what happens in our eyes and our brains. For instance two people look at the leaves of a tree, they might both say that the leaves are green. But could it be that you see them as green, while I see them as a colour closer to your brown, or maybe even your purple? Our eyes sense light, and we think of light as being made up of many waves of different lengths with the shortest wavelengths we can see creating the colour violet, while the longest wavelengths create red. Added to that there are also lots of wavelengths we can't see, which create colours we can't even imagine.

OBJECTS DO NOT EMIT LIGHT

Majority of the objects we see around us do not emit light themselves. Instead, the light from the sun, the moon, or man-made lamps creates the light. Depending on the object, some wavelengths of light will bounce off, while others will be absorbed. So that when we look at an object, our eyes sense the waves of light that have bounced off the object. This all happens very fast, light moves extremely quickly, almost 300 million meters per second or 186 miles per second. You might think that if the colour of an object is decided by the wavelength of light that bounces off it, everyone would see colours the same. But there's more happening in your body, which affects how you see colour.

CELLS AND CONES

This all happens at the back of our eyes in an area covered with a thin layer of cells, which respond to light. The cells in this area at the back of our eyes, which help us to see colour, are called cones. Most people have three kinds of cones in their eyes, S, M, and L cones, each of which only senses light waves of a certain length. When a long wave hits an L cone, it seems to fit into it, like a key in a lock. The cone then contacts its neighbours informing them that it has caught some light, so we say that it is then active.

The L cones only respond to long light waves, so they do not respond to any short or medium ones: those go to the S and M cones.

When light hits the S cones which represent blue they become active, and the same for M which responds to green, while we see red when the wavelength hits the L cones.

Some people have more cone cells and some have less than three kinds of cone cells in their eyes. Some people have four kinds of cones. But for those of us with three, we can not really imagine how they might see the world.

COLOUR BLINDNESS

Also some people only have two kinds of cones, which causes colour blindness. Colour blind people don't see things in black and white; they just have trouble telling the difference between red and green; both could look a shade of brown to them. Dogs also only have two kinds of cones, so they probably also have trouble seeing differences between red and green. But some animals have amazing colour vision.

For example, bees can see shorter wavelengths than humans and use this ability to find the sweet nectar in flowers. The Mimulus flower petals have a dark-coloured "path" to guide bees down to the nectar, which humans cannot see.

SEEING WITH YOUR BRAIN

But it's not just our eyes that see it's our brains. We say we see different colours because of how our brains learn to link the signals they get from the eyes with the names of different colours. We do not know what colour we see but are told what a particular colour is.

When a baby points at a ball and her parents asks, "Would you like to play with that green ball?", the baby learns to associate the colour with the word "green," and will soon call things of a similar colour "green" as well. So if one called the green ball red the baby would associate that colour with red.

BRAIN SEES COLOUR

Many other things can affect how your brain sees colour, including the season, what you looked at before, or the position of your body. Try this experiment to see for yourself:

Lie down on your left side for five minutes with your eyes shut. Now, close your left eye and open your right eye. Then switch eyes. Do things look different when you're using different eyes?

When you laid on your side, more blood went to the lower (left) part of your head and body, and this makes the colours you see with each eye look different.

Can we be sure people see the same colour when they look at some thing? Not at all. While the cones in our eyes suggest we're seeing something similar, it's likely that we all see just a tiny bit differently.

ARTIFICIAL LIGHTING

The type of artificial lighting influence how a colour looks. Halogen is nearly white and the closest to natural light on a clear day around noon. Fluorescent lighting is more bluish, although now some fluorescent bulbs produce a light band close to daylight. Incandescent lighting cast a warm glow that can enhance reds, oranges, and yellows while cool fluorescent light works best with blues, violets, and greens.



WEIRD CRAZY INVENTIONS

THE WINDOW BABY CAGE

This 1922 patented window baby cage was attached to the wall outside of the window suspended from city apartment windows to provide babies with fresh air and sunshine. In the early 1900's, many open air schools were built in an attempt to combat spread of tuberculosis in the belief that open air and ventilation were the key to fighting the epidemic. In 1922, a patent application for a "portable baby cage" was submitted by Emma Read. The cage, into which the baby was placed, was

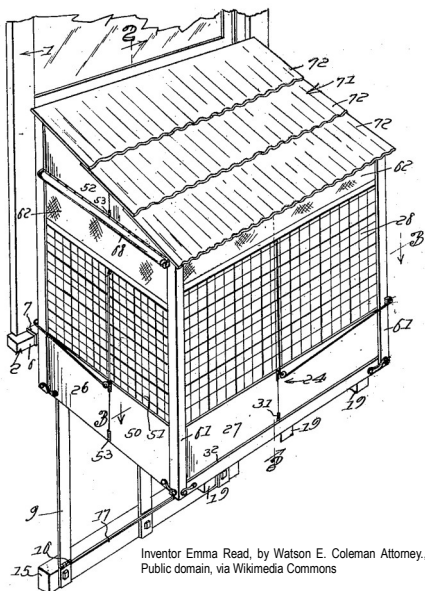

suspended on the external edge of a window.

Use of baby cages gained popularity in London during the 1930s. for children living in gardenless cities. They were given by neighbourhood communities, like the Chelsea Baby Club, to members without a garden.

RIBA APPROVED

The Royal Institute of British Architects dedicated the 'balcons pour bébés'. The London bombing of World War II ended the use of baby cages but they reappeared from 1953. Ultimately, the sale of baby cages progressively declined through the mid-1900s, due to safety concerns and the rise of fumes of urban automobile traffic.

THE RADIO HAT

A leading supplier of party hats, noise makers and other novelty items American Merri-Lei Corporation founder Victor Hoefflich introduced the Radio Hat in 1949

Battery-operated portable radios had been available for many years, but Hoefflich hoped his hat radio, with innovative packaging and a publicity, could be a runaway success. The transistor had just been invented, and it predated the first pocket transistor radio by 5 years.

This radio would have to use the existing vacuum tube technology which were part of the design, like horns, on the top making them a prominent design feature. The loop antenna and the tuning knob were also visible. It was available in eight colours. At a press conference in March 1949, Victor Hoefflich introduced the "Man from Mars, Radio Hat". He knew a picture would tell the story so he hired several teenagers to model it.

WIDESPREAD COVERAGE

It received widespread press coverage in both technical and major consumer publications. The hat was sold in department stores and by mail order. The Van Nuys, California service station chain sold them as a promotion item to customers who purchased petrol. But this massive publicity did not lead to lasting sales. While advertisements for the hat ended in early 1950, Hoefflich said in 1956 the company still got orders for the hat even though it was long out of production. The cover photograph shows a 15-year-old Hope Lange wearing a Lipstick Red hat. She went on to become an award-winning stage, film, and television actress. She was nominated for the 1957 Academy Award for Best Supporting Actress for her role as Selena Cross in the film Peyton Place.

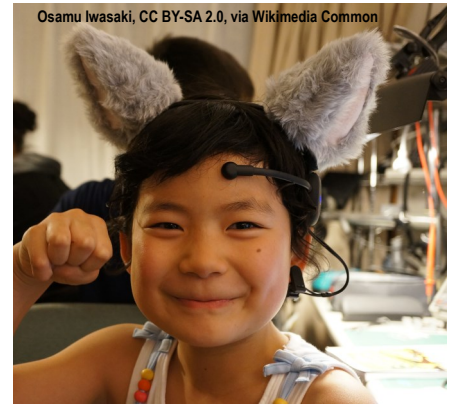

NEUROWEAR

Neurowear is the first project of a Japanese gadget organisation founded on the "Augmented Human Body" concept.

A headband with Mind Wave brain Sensor and motorised cat shaped ears programmed to turn up when the wearer concentrates and to turn down when they relax. Operating for 4 hours on 4 No. AAA batteries it has interchangeable Cat, Dog, and Devil Horn ears. In November 2011, Time Magazine selected necomimi as one of the 50 best inventions of the year and Necomimi received an Honorary Mention in the Interactive Art category of 2013 Prix Ars Electronica.

SPECIALISED EARS

Necomimi was released internationally at the end of 2011. It was demoed at Gadget Show Live in April 2012 and launched in Japan at the Nico Nico Cho-Kaigi at Makuhari Messe in Chiba City on April 28, 2012. Ayaka Komatsu modelled the ears on April 29, 2012. The US price is \$99.95 (£81.00) and was sold at Japan Expo in July 2012 for €150. (£120). Individual crafters create a variety of specialised ear covers, including bear, fox, wolf, bunny and specially commissioned.

Limited edition necomimi were created to promote The Wolf Children Ame and Yuki. The ears' color match the titular wolf children. Another limited edition was created by Nobuki Hizume and modelled by Nagisa Anderson Cooper. A Green Bay Packers fan replaced the ears with cheese wedges. Necomimi premiered in the U.S. at AnimeCon in May 2012, and launched in the U.S. at San Diego Comic-Con International in July 2012. Christina Bonnington reviewed the headband for Wired and Andrew Tarantola reviewed it for Gizmodo.

PHILIPPIDES AND THE MARATHON

When, in 490 BC, Philippides, the Greek messenger who was taking part in the Battle of Marathon, witnessed a Persian vessel changing its course towards Athens as the battle was near a victorious end for the Greek army, and decided to run 25 mile to Athens without stopping, discarding his weapons and clothes to lose as much weight as possible. He burst into the assembly, exclaiming "we have won!". He never thought that, hundreds of years later while his run would be remembered by an annual race in a number of cities virtually now its origin and even less remember his name!

FIRST MARATHON 1896

The modern Olympics began in 1896, when the initiators were looking for a popular event, recalling the glory of ancient Greece. The idea of a marathon race came from Michel Bréal, who wanted the event to feature in the first modern Olympic Games in 1896 in Athens. Supported by Pierre de Coubertin, founder of the modern Olympics, as well as by the Greeks. The winner of the first Olympic marathon, on 10 April 1896 (a male-only race), was Spyridon Louis, a Greek water-carrier, in 2 hours 58 minutes and 50 seconds.

The 2004 Summer Olympics marathon was run on the traditional route from Marathon to Athens, ending at Panathinaiko Stadium, the venue for the first 1896 Summer Olympics. The first wheelchair marathon was in 1974 in Toledo, Ohio, won by Bob Hall in 2:54 He also competed in the 1975 Boston Marathon finishing in 2:58. From 1977 the race was declared the US National Wheel-

chair championship. The Boston Marathon awards \$10,000 (£8,000) to the winning push-rim athlete. Ernst van Dyk has won the Boston Marathon wheelchair division ten times and holds the world record at 1:18:27, in 2004.

The women's marathon was introduced at the 1984 Los Angeles Summer Olympics and won by Joan Benoit of the United States with a time of 2 hours 24 minutes and 52 seconds. Jean Driscoll won eight times and holds the women's world record at 1:34:22.

START AND FINISH

When, as part of the Olympics, it became a tradition for the men's Olympic marathon to be the last event of the athletics calendar, on the final day of the Olympics. For years the race finished inside the Olympic stadium; but at the 2012 London Summer Olympics the start and finish were on The Mall.

Inspired by the success of the first marathon competition in the 1896 Summer Olympics The Boston Marathon 1897 marathon became the world's oldest and ranks as one of the world's most prestigious.

The London Marathon was not the city's first long-distance running event which has a long history of marathon events. The Polytechnic Marathon was first held in 1909.

THE LONDON MARATHON

The London Marathon was proposed in 1981 by Olympic champion and journalist Chris Brasher and athlete John Disley. After completing the New York Marathon in 1979 Brasher wrote an article for The Observer news paper. Held on 29 March 1981, more than 20,000 applied to run. 6,747 were accepted and 6,255 crossed the finish line on Constitution Hill. The race is currently organised by Hugh Brasher, son of Chris, as

Luc-Olivier Merson's 1869 painting depicting the runner announcing the victory at the Battle of Marathon to the people of Athens

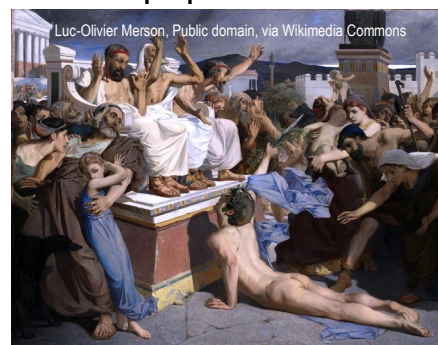

Race Director and Nick Bitel as Chief Executive. Dan Tunstall Pedoe was the medical director of the London Marathon between 1981 and 2005. In 2003, Pedoe was shadowed by Sanjay Sharma from St George's Hospital who took over the role in its entirety in 2006. Medical cover is provided by 150 doctors.

1,500 VOLUNTEERS

Also assisting were more than 1,500 volunteers of St. John Ambulance, who organise over 50 first aid posts along the route, and three field hospitals at the finish. St John Ambulance also provide a number of healthcare professions for the event, including nurses, paramedics, and fully crewed ambulances. For the first time, competitors in the mass participation event could register as non-binary. While there was no elite event for non-binary competitors 118 non-binary competitors signed for the race. There was a virtual marathon held on the same date as the in-person event.

2023 RECORDS

The elite events were won by Kelvin Kiptum and Sifan Hassan in times of 2:01:25 and 2:18:33 respectively; Kiptum's time was a course record. The wheelchair competitions were won by Marcel Hug and Madison de Rozario in course record times of 1:23:44 and 1:38:51 respectively. 48,000 finished the mass participation event, beating the 2019 record.

The BBC covers the event, devoting rolling coverage for most of the morning. The theme music associated with the event is Main Titles to The Trap composed by Ron Goodwin for the film The Trap. In the United Kingdom, the races were broadcast on BBC One, and broadcast in 197 countries.

Route of the London Marathon from Blackheath to The Mall

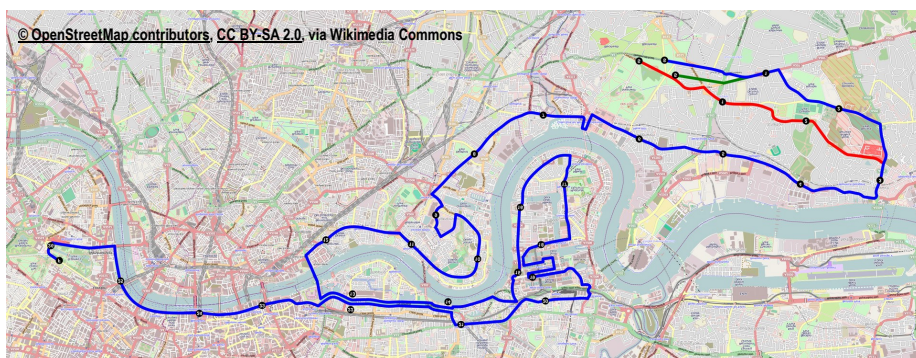

ARE THESE THE OLDEST PROFESSIONS?

No one can say which is the oldest but there a number which it is obvious are some of the first. It has often been said that the world's oldest profession is prostitution and the second is spying as they are mentioned in the Bible! The first must all relate to those based on the human needs but it is impossible to decide which. So here are a few suggestions.

For this list, one needs to cover professions that would have emerged as a result of first human creations such as tools, art, language, and agriculture. All of these jobs still exist in some form and probably always will because they deal with some of the most basic human needs.

ARTISTS

The oldest known art in the world is a cave painting of a red hand stencil from Spain. The cave painting is estimated to be over 67,000 years old and was made by a Neanderthal. Although this is the earliest evidence

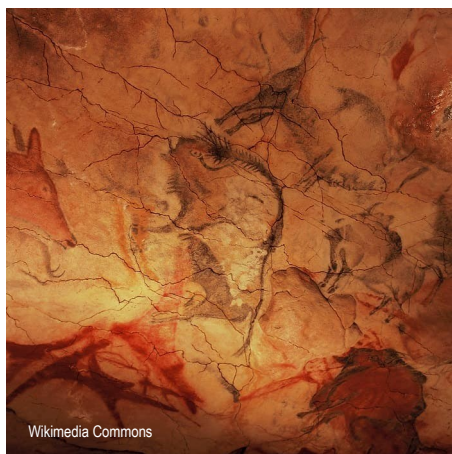

of art, researchers believe that humans already had the ability to make art before they left Africa over 65,000 years ago – ancient art from Africa is hard to find because the geology doesn't preserve it. Ancient art mostly depicted everyday life and featured people and the animals in their surroundings.

TOOLMAKERS

The earliest human ancestors began making stone tools about 2.6 million years ago, which means that toolmaker is one of the oldest pro-

fession in the world. The oldest stone tools are known as Oldowan and included not only chunks of rock used for pounding, but also sharp flakes made from quartz, obsidian, or flint. These tools are believed to have been used to butcher animals. The emergence of tools in human history eventually led to



the evolution of homo sapiens (modern humans), who became so adept at making and using tools that we are now the last remaining hominid species.

BUILDERS

Shelter was the most basic human need and while everyone had to build what they could from what was available there is evidence, through many building being the same, that there must have been some who were more able than

Reputed to be the oldest advertisement for a brothel in Ephesus; a stone slab set in the pavement dating from the 1st Century A.D Interpretation suggests that the foot points the way and, above that, a cross, which is hard to see, believed to represent an intersection.

The size of the foot indicates that if your foot was smaller, you were too young and the left foot indicates that the brothel was on the left. The depiction of a woman tells us what one can find there with the coin-filled purse, indicates payment for her affection.



others. Humans moved from a nomadic hunter-gatherer lifestyle over 10,000 years ago. Established permanent homes initially built by their inhabitants, but specialist builders emerged as people developed more defined roles in society.

TAILORS

There is no direct evidence that tells us when our ancestors stopped wandering around naked and when ancient humans started wearing clothing. But anthropologists estimate that clothing came about between 100,000 to 500,000 years ago if only animal skins to keep warm or perhaps as modesty garments. However, a 2011 study on lice suggests that early humans were wearing clothes as early as 170,000 years ago. The oldest sewing needles date back to between 41,000 – 60,000 years ago. Early clothing was simple and primarily worn by hominid species that live in colder climates.

FARMERS

Our ancestors were collecting and eating wild grains from at least 20,000 BCE, but they did not start to cultivate crops until about 12,000 – 13,000 years ago. Rye was one of the first grains people from Mesopotamia tried to farm.

Around 9,500 BCE, the eight “founder crops” — emmer wheat, einkorn wheat, hulled barley, peas, lentils, bitter vetch, chickpeas, and flax — were cultivated by different groups in the Fertile Crescent.

STORY TELLERS

The origins of human language are completely unknown as it is impossible to trace the history of spoken languages. Scholars are not sure which hominid species was the first to develop proto-language skills.

The best estimates put the development of language among modern humans at less than 200,000 years ago. Oral storytelling is probably as old as the human language. It was how our ancestors passed down important information and explained the world around them.

The practice of oral storytelling persisted even after development of written language about 3100 BC

Modern storytelling has come a long way from its ancient roots and exists today in many media styles such as books, TV shows, movies, video games, blogs, and viogs.